

NF3A00B15AP300TBI

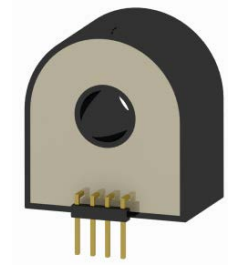

Main characteristics:

- Nominal current measurement: from $\pm 3A$ DC, AC
- Excellent linearity: 15 ppm
- High resolution
- Very low offset drift
- Overall accuracy at I_{PN} @ $+25^{\circ}C$: $\leq \pm 0.1\%$
- Wide frequency bandwidth up to 300 kHz (-1 dB)
- ROHS Compliant

Features:

- DC, AC pulse currents' measurements with galvanic isolation
- Nano Crystal Fluxgate technology
- Electrostatic shield between primary and secondary circuit
- Bipolar Power supply ± 15 Volt
- Operating temperature range from -20 to $+85^{\circ}C$
- Wire Connector Type
- Current output
- Really quick response time (< 300 ns)

Standard compliance:

- Typical applications:
- Feedback element in precision current regulated devices (power supplies...)
- Precise and high stability inverters
- Medical equipment
- Energy measurement
- Power analyzers

Remarks:

- Current overload capability
- Additional output indicating the transducer state

Specification

Nominal primary current (I_{PN})	± 3	A r.m.s.
Measuring range @ $\pm 15V$ ($\pm 5\%$)	± 10	A peak
Max. measuring resistance @ I_P max & $\pm 15V$ ($\pm 5\%$)	300	Ω
Min. measuring resistance @ I_{PN} & $\pm 15V$ ($\pm 5\%$)	100	Ω
Turn number	300	Turn
Secondary current at I_{PN}	3/300	A
Accuracy at I_{PN} @ $+25^\circ C$	$\leq \pm 0.1$	%
Accuracy at I_{PN} @ $-5 \sim +85^\circ C$	$\leq \pm 0.2$	%
Accuracy at I_{PN} @ $-20 \sim +85^\circ C$	$\leq \pm 0.5$	%
Offset current @ $+25^\circ C$	$\leq \pm 100$	μA
Linearity	$\leq \pm 0.05$	%
Thermal drift coefficient @ $-5 \sim +85^\circ C$	≤ 2	$\mu A/^\circ C$
Thermal drift coefficient @ $-20 \sim +85^\circ C$	≤ 5	$\mu A/^\circ C$
Delay time	≤ 0.5	μs
di/dt correctly followed	≤ 60	A/ μs
Bandwidth @ -1dB	≤ 300	kHz
Max. no-load consumption current @ $\pm 15V$ ($\pm 5\%$)	≤ 20	mA
Secondary resistance @ $+85^\circ C$	≤ 30	Ω
Dielectric strength Primary/Secondary @ 50Hz, 1min	3	kV
Supply voltage @ $\pm 20\%$	$\pm 15V$	V dc
Voltage drop	≤ 3	V
Mass	0.019	kg
Operating temperature	$-20 \sim +85$	$^\circ C$
Storage temperature	$-25 \sim +125$	$^\circ C$

General data

- Plastic case and insulating resin are self-extinguishing.
- Fixing holes in the case molding for two positions at right angles
- Direction of the current: A primary current flowing in the direction of the arrow results in a positive secondary output current from terminal C_{OUT} .

Dimensions

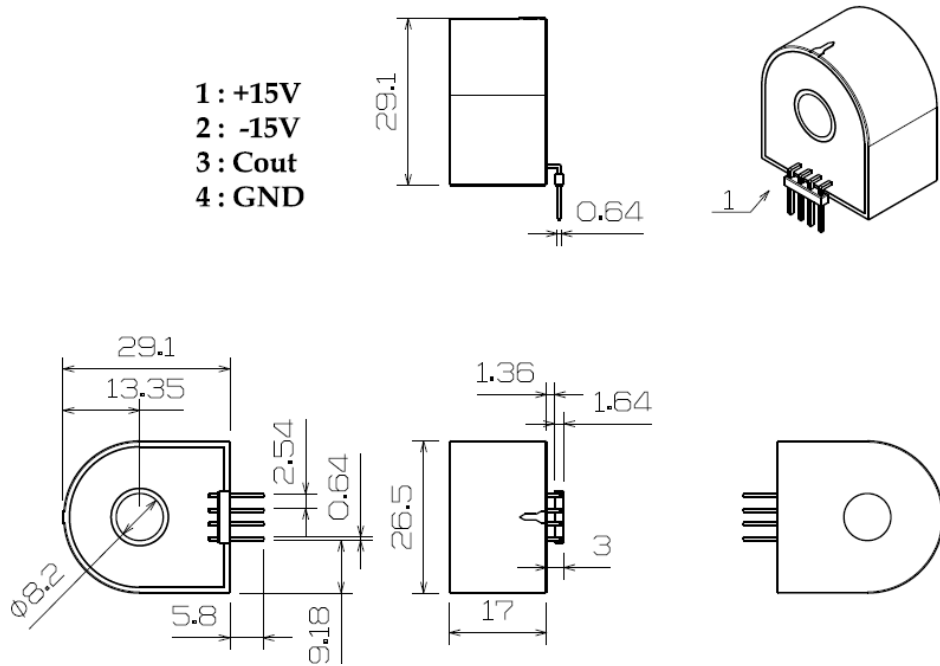

- 1 : +15V
- 2 : -15V
- 3 : Cout
- 4 : GND

Installation

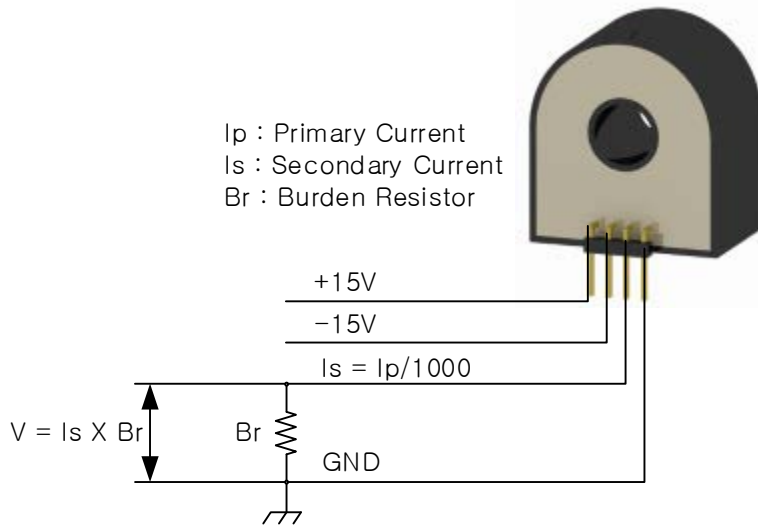

* The positive direction of the current from the front to the rear of the head (the front of the contactor).

(Secondary_Resistance + Measuring_Resistance) x Max_Secondary_Current + 1V = 12V

Measuring_Resistance = (12 - 1) / Max_Secondary_Current - Secondary_Resistance

Therefore, Measuring_Resistance = 11/(10/300) - 30 = 300 Ω

Caution

Be careful not to operate under 100Ω burden resistor. The current sensor is damaged.